

RELEASED

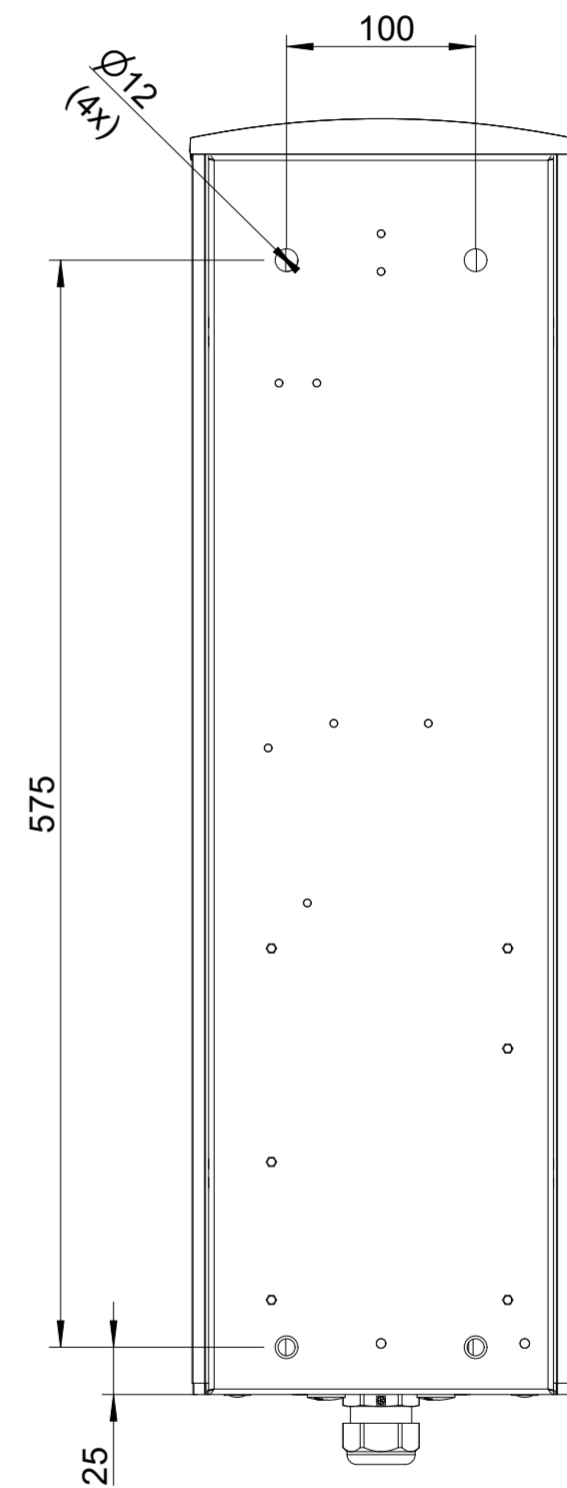

PDM-Modellidokument TECHNAGON-TEW3_3-2	Erstellt Oliver Krieger	05.06.2024	Gändert Oliver Krieger	01.08.2024	Genehmigt Thomas Zelzer	01.08.2024-10:30 MESZ	Lebenszyklus-Status Freigegeben	Revision -
Änderungsnr.:	Maße nach DIN EN ISO 14405		Allgemeintoleranzen ISO 2768-m		Oberfläche ISO 1302		Werkstoff -	
			Kanten ISO 13715		Beschichtung --			
Artikelnummer Halbbezugn. Halbbezug	TECHNAGON-TEW3_3 -		Benennung (Modell) Technagon TEW3		Zusatzdokument Massübersicht			Masse 11.92 kg
			Zeichnungsnummer TECHNAGON-TEW3_3					
	Projektnummer P0296	Verkaufsnummer -	Maßstab 1:4	Ersatz für -	Sprache DE	Blatt 1/1		

technagon

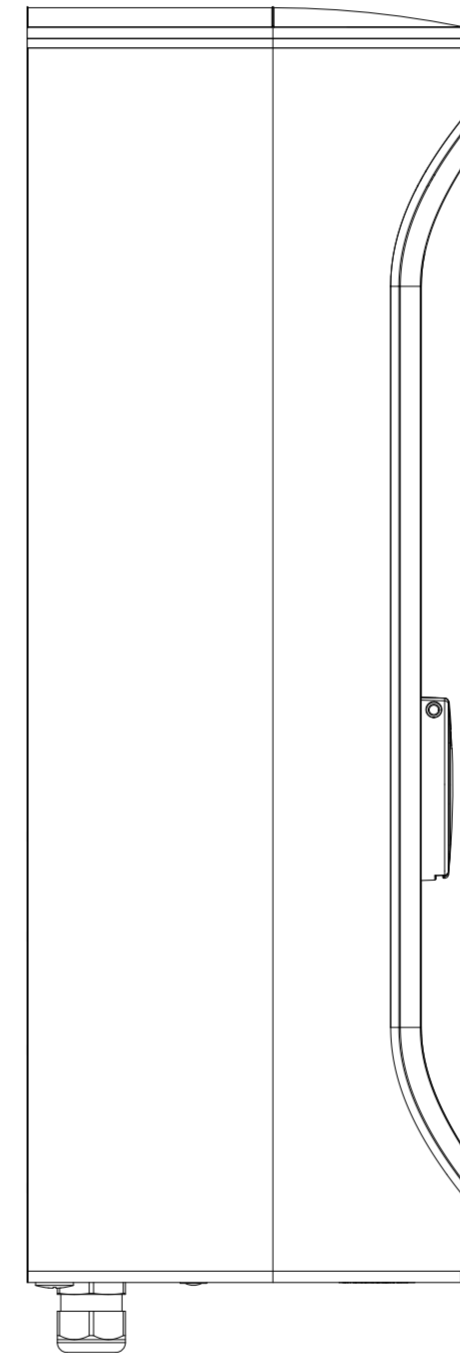
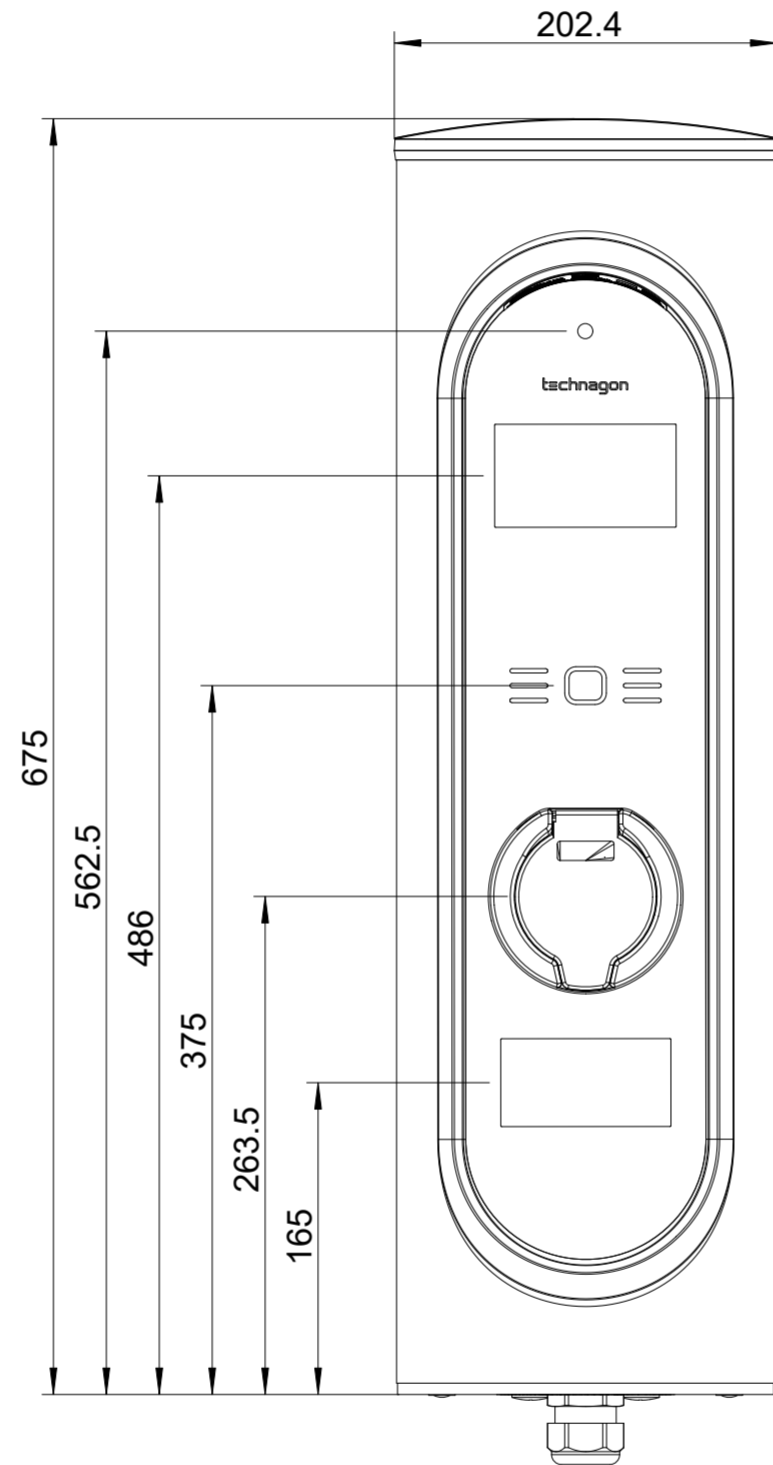
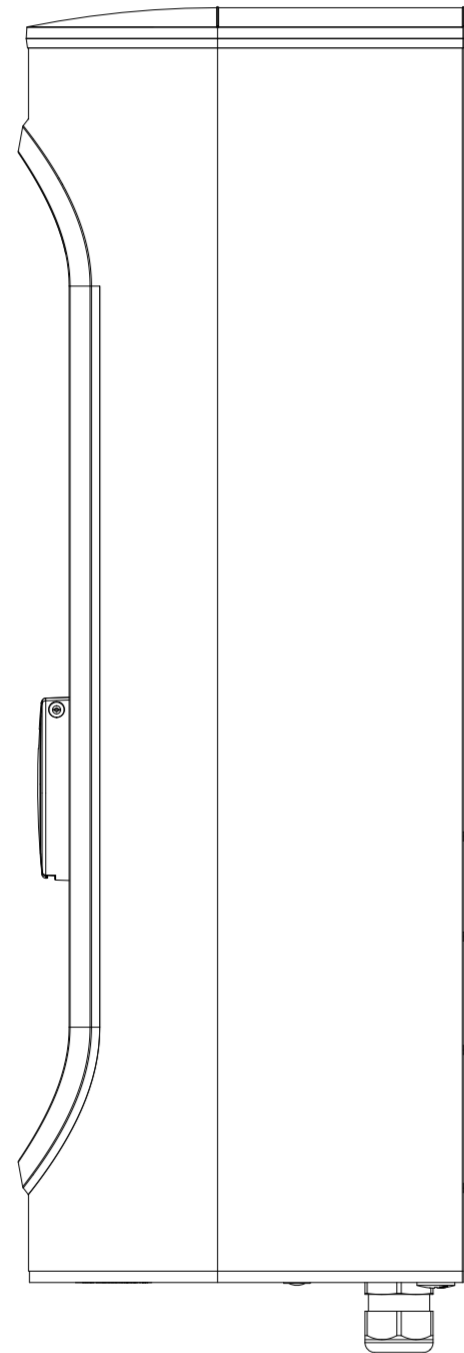
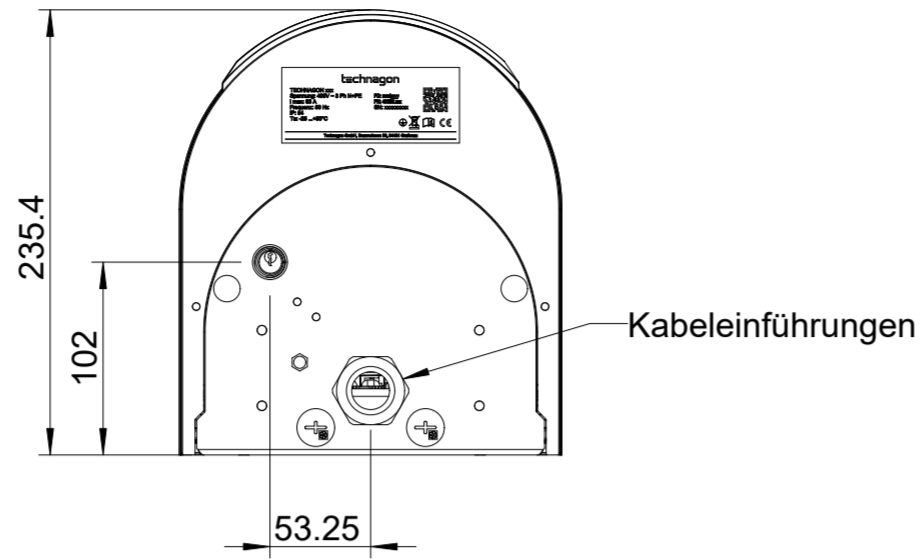
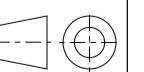

Blatt 1/1

A2